

Squire[®]

Stainless Steel Indirect Water Heater

Installation & Operation Manual

Models: SIT030 - SIT119



⚠ WARNING

This manual must only be used by a qualified heating installer / service technician. Read all instructions before installing. Perform steps in the order given. Failure to comply could result in severe personal injury, death, or substantial property damage.

Save this manual for future reference.



Lochinvar[®]
High Efficiency Water Heaters, Boilers and Pool Heaters

Contents

HAZARD DEFINITIONS	2	Install Drain Valve	12
PLEASE READ BEFORE PROCEEDING	3	Temperature and Pressure (T&P) Relief Valve	12
1. GENERAL INFORMATION		Table 4A - Minimum Relief Valve (AGA Rating) ..	13
Operating Restrictions	4	5. WIRING	
Single-Wall Heat Exchanger	4	Indirect Water Heater Sensor Setup (Knight Boiler)	15
2. PRE-INSTALLATION		Install Tank Sensor	15
Locating the Tank	5	Indirect Water Heater Controlled Using Aquastat and Zone Circulator	16
Recommended Clearances	5	6. START-UP AND CHECK-OUT	17
3. BOILER SIDE PIPING		7. MAINTENANCE	
Zone with Circulator to Aquastat	6	Maintenance Schedule	18
Zone with Valve to Aquastat	6	To Fill the Water Heater	18
DHW Prioritization	6	To Drain the Water Heater	18
Multiple Tank Connections (Boiler Side)	6	8. PERFORMANCE DATA	
Table 3A - Pressure Drop Chart	6	IBR Chart	19
Table 3B - Pressure Drop Values	6	How to Properly Size Your Indirect Water Heater	20
Piping Diagrams	7-10	Performance Data Charts	21-23
4. DOMESTIC SIDE (TANK) PIPING		REVISION NOTES	Back Cover
Basic Domestic Piping	11		
Multiple Tank Domestic Water Piping	11		
Domestic Water Piping for Distant Fixtures	11		
Anti-scald Valves (Mixing Valves)	12		

Hazard definitions

The following defined terms are used throughout this manual to bring attention to the presence of hazards of various risk levels or to important information concerning the life of the product.

⚠ DANGER

DANGER indicates an imminently hazardous situation which, if not avoided, will result in death or serious injury.

⚠ WARNING

WARNING indicates a potentially hazardous situation which, if not avoided, could result in death or serious injury.

⚠ CAUTION

CAUTION indicates a potentially hazardous situation which, if not avoided, may result in minor or moderate injury.

CAUTION

CAUTION used without the safety alert symbol indicates a potentially hazardous situation which, if not avoided, may result in property damage.

NOTICE

NOTICE indicates special instructions on installation, operation, or maintenance that are important but not related to personal injury or property damage.

Please read before proceeding

⚠ WARNING **Installer** – Read all instructions before installing. Perform steps in the order given.

Have this indirect water heater serviced/inspected by a qualified service technician, at least annually.

Failure to comply with the above could result in severe personal injury, death or substantial property damage.

NOTICE When calling or writing about the appliance – Please have the indirect water heater model and serial number from the indirect water heater rating plate.

Consider piping and installation when determining appliance location.

Any claims for damage or shortage in shipment must be filed immediately against the transportation company by the consignee.

Factory warranty (shipped with appliance) does not apply to appliances improperly installed or improperly operated.

⚠ WARNING If the information in this manual is not followed exactly, a fire or explosion may result causing property damage, personal injury or loss of life.

This appliance **MUST NOT** be installed in any location where gasoline or flammable vapors are likely to be present.

WHAT TO DO IF YOU SMELL GAS

- Do not try to light any appliance.
- Do not touch any electric switch; do not use any phone in your building.
- Immediately call your gas supplier from a neighbor's phone. Follow the gas supplier's instructions.
- If you cannot reach your gas supplier, call the fire department.
- Installation and service must be performed by a qualified installer, service agency, or the gas supplier.

⚠ WARNING Failure to adhere to the guidelines on this page can result in severe personal injury, death, or substantial property damage.

When servicing the indirect water heater –

- To avoid severe burns, allow the appliance to cool before performing maintenance.

Indirect water heater operation –

- Should overheating occur or gas supply fail to shut off, do not turn off or disconnect electrical supply to circulator. Instead, shut off the gas supply at a location external to the appliance.
- Do not use this appliance if any part has been under water. The possible damage to a flooded appliance can be extensive and present numerous safety hazards. Any appliance that has been under water must be replaced.

The following chart details the relationship of water temperature and time with regard to scald injury and may be used as a guide in determining the safest water temperature for your applications.

APPROXIMATE TIME / TEMPERATURE RELATIONSHIPS IN SCALDS	
120°F	More than 5 minutes
125°F	1 1/2 to 2 minutes
130°F	About 30 seconds
135°F	About 10 seconds
140°F	Less than 5 seconds
145°F	Less than 3 seconds
150°F	About 1 1/2 seconds
155°F	About 1 second



Hot Water Can Scald!

- Water heated to temperatures for clothes washing, dish washing, and other sanitizing needs can scald and cause permanent injury.
- Children, elderly, and infirm or physically handicapped persons are more likely to be permanently injured by hot water. Never leave them unattended in a bathtub or shower. Never allow small children to use a hot water tap or draw their own bath.
 - If anyone using hot water in the building fits the above description, or if state laws or local codes require certain water temperatures at hot water taps, you must take special precautions:
 - Use lowest possible temperature setting.
 - Install some type of tempering device, such as an automatic mixing valve, at hot water tap or water heater. Automatic mixing valve must be selected and installed according to valve manufacturer's recommendations and instructions.
- Water passing out of drain valves may be extremely hot. To avoid injury:
 - Make sure all connections are tight.
 - Direct water flow away from any person.

Protection Must Be Taken Against Excessive Temperature and Pressure!
--Installation of a Temperature & Pressure (T&P) relief valve is required.

1 General Information

The Lochinvar SIT series indirect water heater (FIG. 1-1) is designed to generate domestic hot water in conjunction with a hot water boiler using forced boiler water circulation. This indirect water heater consists of a 316L Stainless Steel tank in which a smooth 304L stainless steel coil is located (Table 1A). Boiler water is pumped through the coil and heats the water in the tank. This tank is not intended for use in pool heating applications or for heating any fluid other than water. It is also not intended for use in gravity hot water heating systems.

Operating Restrictions:

- Maximum domestic hot water temperature is 194°F.
- Maximum boiler water temperature is 210°F.
- Maximum working pressure for the vessel tank is 150 psig.

Component	Material
Tank	316L Steel Stainless Steel
Coil	304L Stainless Steel
Insulation	Polyurethane
Jacket	ABS

Single-Wall Heat Exchanger

National Standard Plumbing Code

Single-wall heat exchangers in water heaters comply with the National Standard Plumbing Code provided that:

- boiler water (including additives) is practically non-toxic, having a toxicity rating or class of 1, as listed in Clinical Toxicology of Commercial Products, and
- boiler water pressure is limited to a maximum of 30 psig by approved relief valve.

Uniform Plumbing Code

Single-wall heat exchangers are permitted if they satisfy all of the following requirements --

1. The heat transfer medium is potable water or contains only substances which are recognized as safe by the U.S. Food and Drug Administration.
2. The pressure of the heat transfer medium is maintained less than the normal minimum operating pressure of the potable water system.
3. The equipment is permanently labeled to indicate that only additives recognized as safe by the FDA shall be used in the heat transfer medium.

Other heat exchanger designs may be permitted where approved by the Administrative Authority.

Figure 1-1 Lochinvar SIT Series Indirect Water Heater

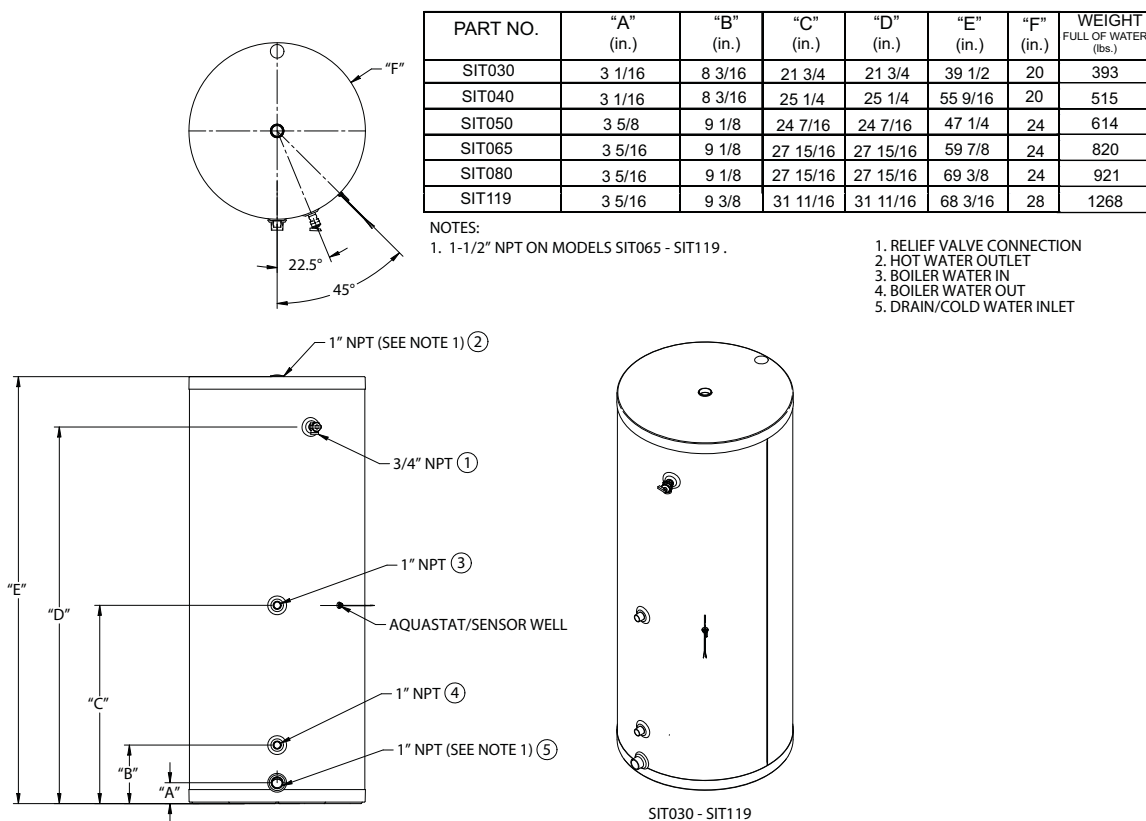

2 Pre-installation

1. The installation must conform to the instructions in this manual and all applicable local, state, provincial, and national codes, laws, regulations, and ordinances. Installations in Canada must conform to B149.2 Installation Code.
2. Be certain the domestic water supply to the tank has physical and chemical characteristics that fall within the limits shown in Table 2A. Where questions exist as to the composition of the water on the job, a qualified water treatment expert should be consulted.

CAUTION

Water with characteristics outside the limits shown in Table 2A may severely shorten the life of the tank due to corrosion. Damage to tanks in such cases is not covered under warranty.

3. Read and understand all installation requirements in this manual.

Table 2A Water Chemistry Requirements		
Water used in the tank must have characteristics falling within the following limits:		
Characteristic	Min.	Max.
Ph	6.0	8.0
Chloride (PPM)	--	80

Locating the Tank

1. Choose a location for your water heater centralized to the piping system. You must also locate the SIT water heater where it will not be exposed to freezing temperatures. Additionally, you will need to place the water heater so that the controls, drain, and inlet/outlets are easily accessible. This appliance must not be installed outdoors, as it is certified as an indoor appliance, and must also be kept vertical on a level surface.
2. Keep distance between boiler and water heater to a minimum to:
 - a. reduce piping heat loss
 - b. provide minimal friction loss
3. Figure 1-1 on page 4 shows the weights of all the tanks filled with water. Make sure that the location chosen for the tank is capable of supporting it.

CAUTION

This appliance must be placed where leakage from the relief valve, leakage from the related piping, or leakage from the tank or connections, will not result in damage to the surrounding areas, or to the lower floors of the building. A water heater should always be located in an area with a floor drain or installed in a drain pan suitable for water heaters. Lochinvar shall not be held liable for any such water damage.

4. The tank may be located some distance from the boiler provided the pump is designed to provide the flow called for in Table 3B - Pressure Drop Values, through the coil. Also, the further the tank is from the boiler, the longer the response of the boiler will be to a call from the tank zone. Insulate piping between the boiler and the tank.

WARNING

Failure to properly support the tank could result in property damage or personal injury.

Recommended Clearances

The installation location must provide adequate clearances for servicing and proper operation of the water heater. A 12 inch vertical clearance is recommended from the top of the water heater. A zero clearance is allowed for the sides of the water heater. However, boiler and servicing clearances must be figured when locating the water heater.

3 Boiler Side Piping

Figures 3-1 thru 3-4 show typical boiler side piping for several common situations. Regardless of which system is used it is imperative that the flow rates called for in Table 3B are developed through the coil. This requires properly sized piping and a properly sized pump.

The system shown in FIG's 3-1 thru 3-4 are described below:

Zone with Circulator to Aquastat

This system is like the circulator zone system on a straight heat job except that one of the zones goes to the tank instead of radiation. As on any circulator zone system check valves should be installed in each zone to prevent unwanted circulation through zones which are not calling for heat. Figure 3-1 on page 7 illustrates typical circulator zone piping.

Zone with Valve to Aquastat

As with the circulator zone system, this system is just like a standard heating zone system except that one of the zones is connected to the tank coil as shown in FIG. 3-2. The system circulator must be large enough to move boiler water through the coil regardless of the flow rate required through the heating zones.

DHW Prioritization

This piping system is designed to provide direct hot water priority over the other zones in the heating system. When there is a Domestic Hot Water (DHW) call for heat, the Knight control will shut off the boiler circulator and activate the domestic hot water circulator. Once the DHW demand is satisfied, the boiler circulator will be readjusted as demand requires. The circulator must be large enough to move the boiler water through the coils. The recommended piping for a DHW priority system is depicted in FIG. 3-3 on page 9.

Multiple Tank Connections (Boiler Side)

Multiple tank installations must be done in the "reverse-return" manner. The reason for this is to create the same pressure drop (and therefore, the same flow) through the coil of each tank. The boiler manifold piping must be sized so that each coil has the flow rate called for in Table 3B.

Because the pressure drop through tank coils varies from size to size, it is hard to predict the flow rate that will be developed through each coil when two tanks of different sizes are placed in the same manifold. For this reason it is best not to mix tanks of different sizes in the same zone if their recovery is critical.

**Table 3A
 Pressure Drop Chart**

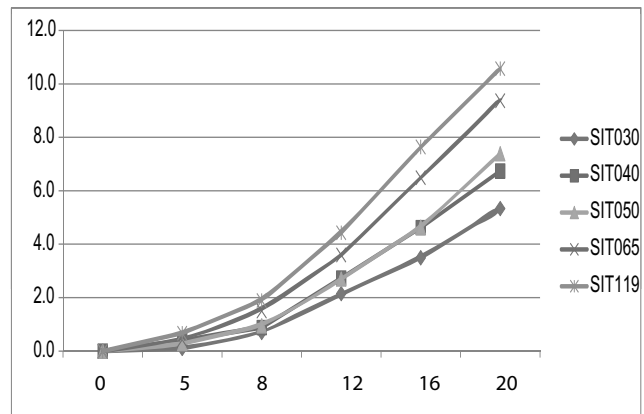

MODEL	WATER INLET (NPT)	WATER OUTLET (NPT)	COIL CONNECTION (NPT)	COIL LENGTH (FT)	SQ FT SURFACE AREA	PRESSURE DROP (FT/HD)				
						5 GPM	8 GPM	12 GPM	16 GPM	20 GPM
SIT030	1	1	1	24	8.0	.1	.7	2.2	3.5	5.3
SIT040	1	1	1	30.8	10.0	.4	.9	2.7	4.6	6.7
SIT050	1	1	1	36.5	12.0	.3	1.0	2.7	4.6	7.4
SIT065	1.5	1.5	1	41.5	13.5	.4	1.5	3.6	6.5	9.4
SIT080	1.5	1.5	1	41.5	13.5	.4	1.5	3.6	6.5	9.4
SIT119	1.5	1.5	1	67.3	22.0	.7	1.9	4.4	7.6	10.6

3 Boiler Side Piping (continued)

Figure 3-1 Piping Diagram Zoned with Circulators

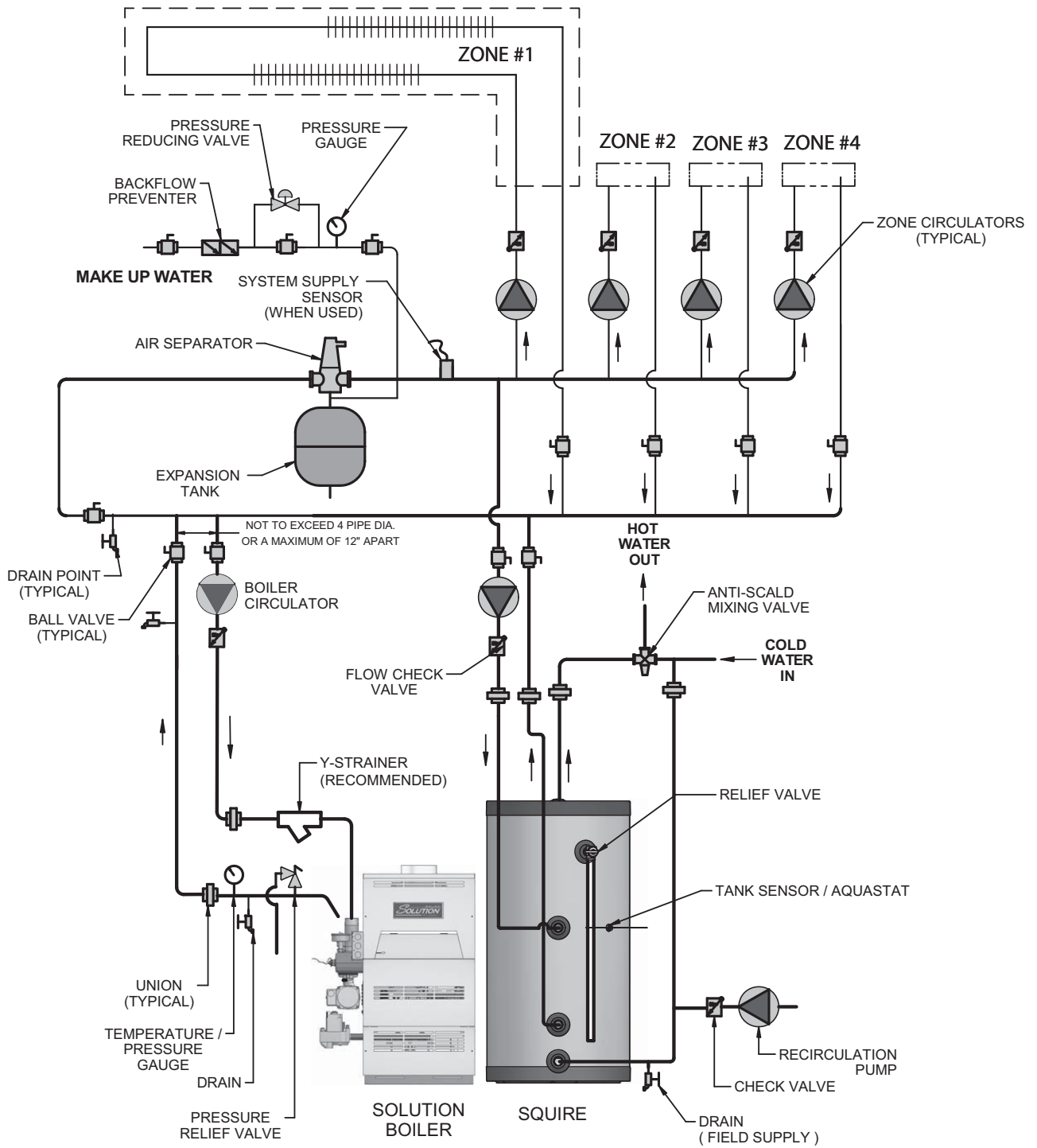

NOTICE Please note that these illustrations are meant to show system piping concept only, the installer is responsible for all equipment and detailing required by local codes.

3 Boiler Side Piping

Figure 3-2 Piping Diagram Zoned with Valves

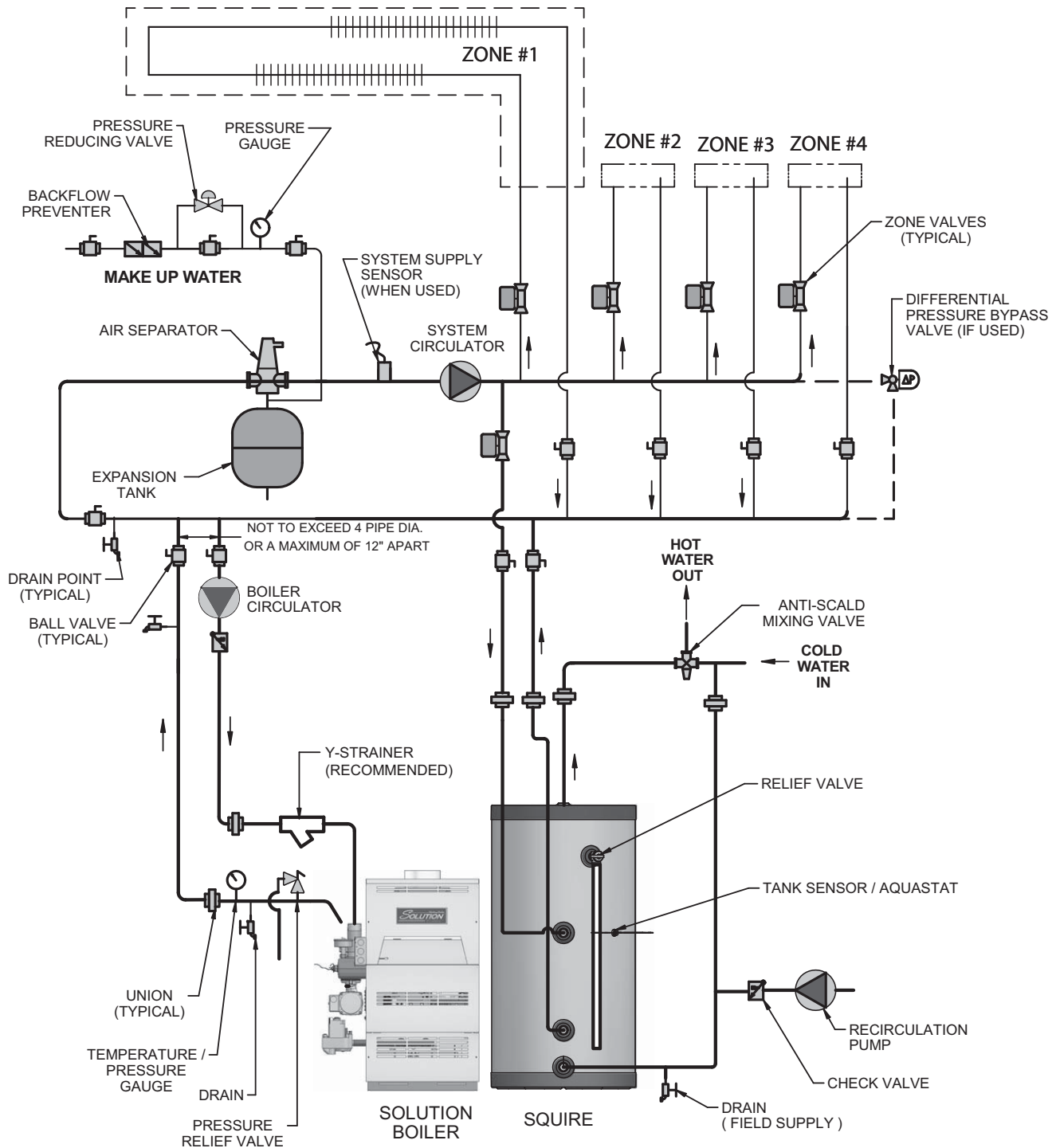

NOTICE

Please note that these illustrations are meant to show system piping concept only, the installer is responsible for all equipment and detailing required by local codes.

3 Boiler Side Piping *(continued)*

Figure 3-3 Knight Boiler Primary / Secondary Piping

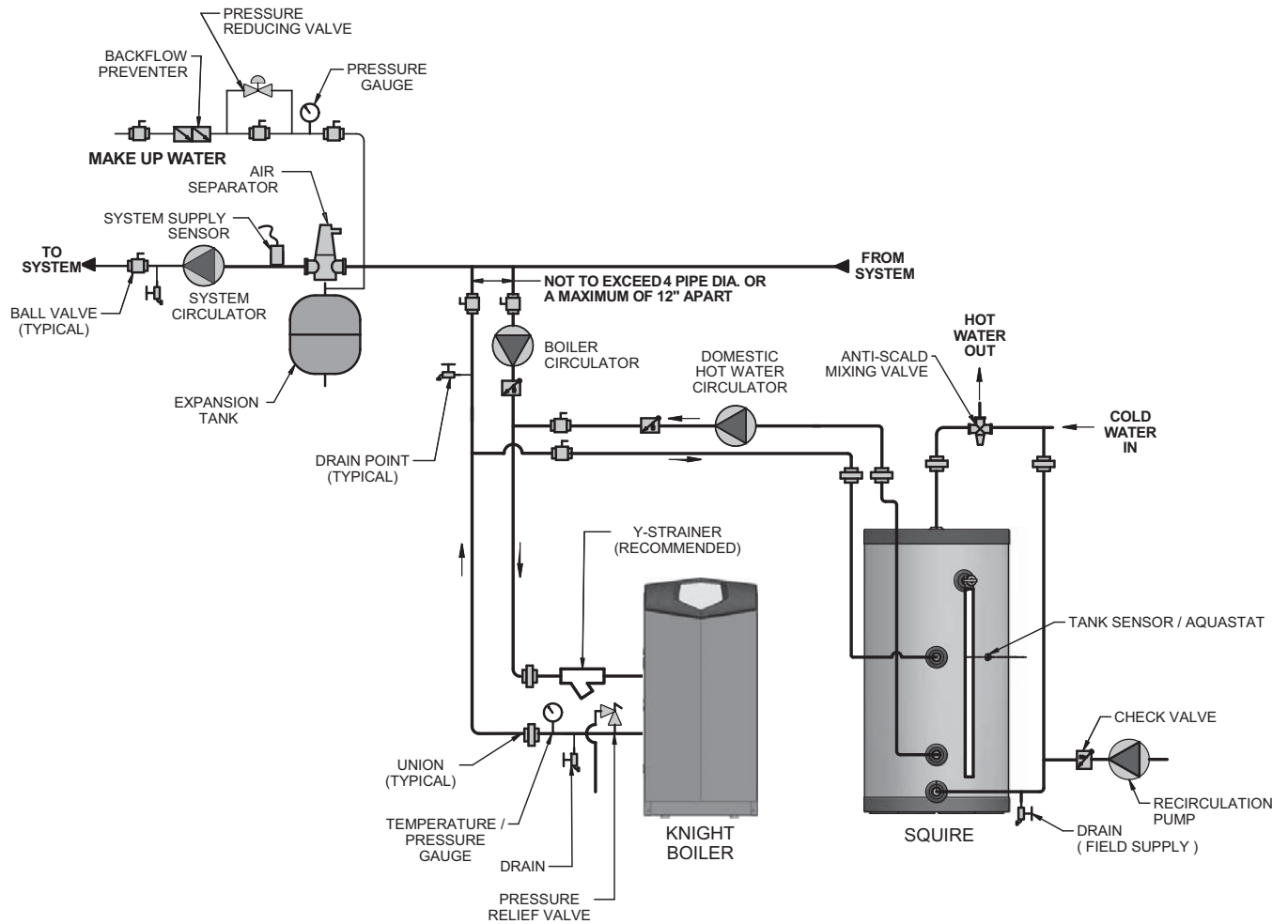

NOTICE

Please note that these illustrations are meant to show system piping concept only, the installer is responsible for all equipment and detailing required by local codes.

3 Boiler Side Piping

Figure 3-4 Multiple Tank Connections

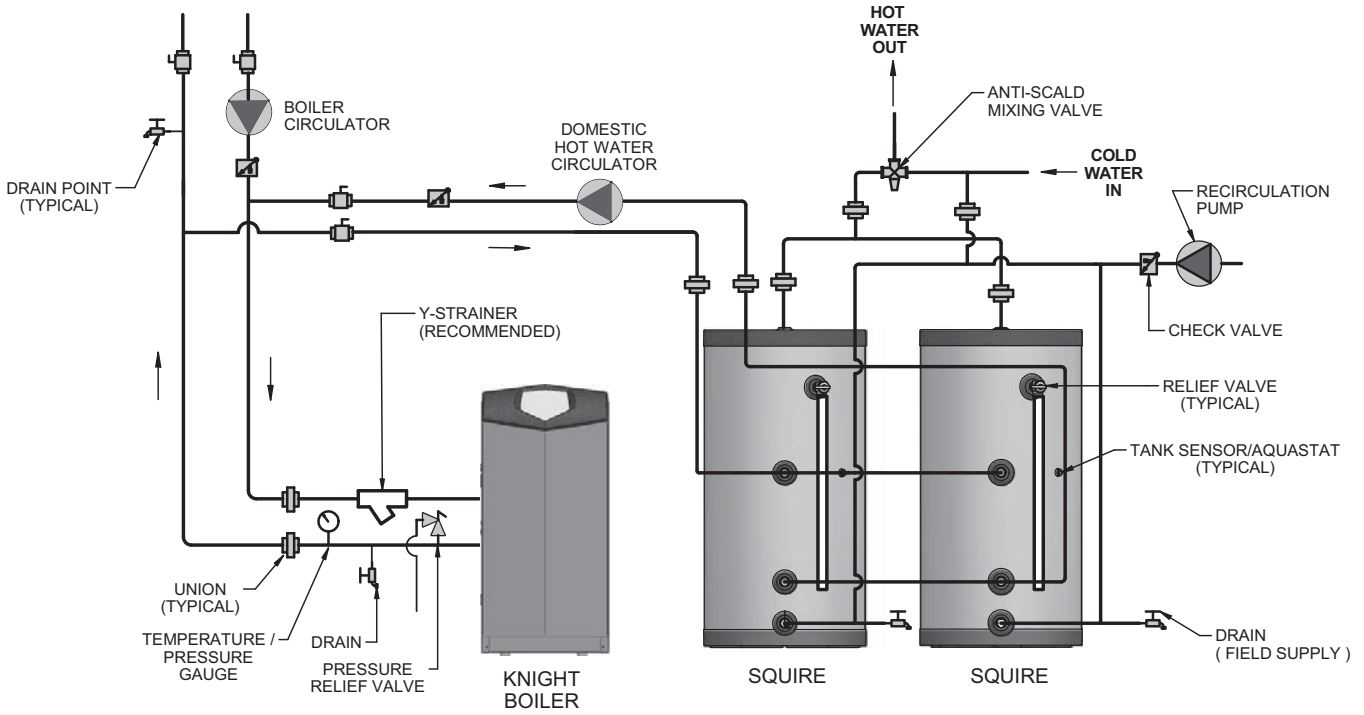

NOTICE Please note that these illustrations are meant to show system piping concept only, the installer is responsible for all equipment and detailing required by local codes.

4 Domestic Side (Tank) Piping

Basic Domestic Piping

Figure 4-2 on page 14 shows typical domestic water piping for a tank. The function of the components shown are as follows:

- a. Shut-off valves (recommended) - Used to isolate the tank for servicing.
- b. Backflow Preventer (required by some codes) - Used to prevent water from backing out of the tank in the event that inlet water pressure drops.
- c. Expansion Tank (required when a backflow preventer is used) - This expansion tank absorbs the increased volume caused by heating water.

Use an expansion tank designed for use on domestic water systems. Refer to the expansion tank manufacturer's literature for the proper size expansion tank to use.

NOTICE

If an expansion tank is used, do not put any valves between the expansion tank and tank inlet.

- d. Unions (optional) - Used to disconnect the tank in the unlikely event that this is necessary.
- e. Drain (required) - Used to drain the tank for inspection or servicing.

Multiple Tank Domestic Water Piping

The two pipe reverse return piping uses more pipe than the two pipe direct return piping, but the flow is more balanced and even in the two pipe reverse return piping layout (see FIG. 3-4).

Each tank must have its own T&P valve. It is recommended that each tank be equipped with its own isolation valves, unions, and drains so that one tank may be removed from the system. If local codes require a backflow preventer, check with the appropriate authority to find out whether one backflow preventer may be used for tanks or each tank must be equipped with its own backflow preventer. If each tank must have its own backflow preventer, each tank must also have its own expansion tank. If a common backflow preventer is permitted, an expansion tank must be sized to accommodate the expansion volume of all tanks.

Domestic Water Piping for Distant Fixtures

In some cases the furthest fixture may be quite distant from the tank. Such an installation would result in an unacceptable delay before hot water reaches these distant fixtures. Even if all the fixtures are relatively close to the tank, the building owner may want hot water at all fixtures as soon as they are opened.

Return circulation piping with a check valve that allows flow to the inlet of the tank. This should be installed on each branch, at the furthest fixture or device, so that hot water is supplied upon demand.

Because hot water is always circulating in the hot water branch the entire branch should be insulated to prevent excessive heat loss.

4 Domestic Side (Tank) Piping

Anti-scald Valves (Mixing Valves)

Anti-scald valves used with water heaters are also called tempering valves or mixing valves. An anti-scald valve mixes cold water in with the outgoing hot water to assure that hot water reaching a building fixture is at a temperature low enough to be safe.

Usually, the maximum temperature of the outlet water will stay near the setting of the tank control. In some cases, however, hot water usage patterns can cause the outlet water temperature to rise significantly above the control setting.

The temperature of water going to the fixtures may be more carefully controlled through the use of a thermostatic mixing valve. This device blends a controlled amount of cold water with the hot water leaving the tank so that water at a more constant temperature exits the mixing valve. Anti-scald mixing valve piping is illustrated in FIG.'s 3-1 thru 3-4.

⚠ WARNING

An anti-scald mixing valve does not eliminate the risk of scalding.

- * Set the tank thermostat as low as practical.
- * Feel water before bathing or showering.
- * If anti-scald or anti-chill protection is required, use devices specifically designed for such service. Install these devices in accordance with their manufacturer's instructions.

Install Drain Valve

Drain valve and fittings are supplied by others.

Standard Installation

- Install a tee connection at the domestic cold water inlet (FIG. 4-1).

Figure 4-1 Drain Valve Installed

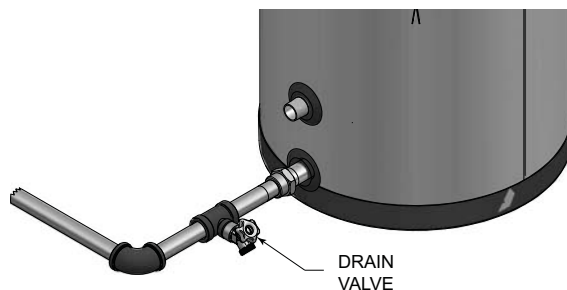

Temperature & Pressure (T&P) Relief Valve

⚠ WARNING

For protection against excessive temperatures and pressure, install temperature and pressure protective equipment required by local codes, but not less than a combination temperature and pressure relief valve certified by a nationally recognized testing laboratory that maintains periodic inspection of production of listed equipment or materials as meeting the requirements for Relief Valves and Automatic Gas Shutoff Devices for Hot Water Supply Systems, ANSI Z21.22 and the Standard CAN1-4.4, Temperature, Pressure, Temperature and Pressure Relief Valves and Vacuum Relief Valves. The combination temperature and pressure relief valve shall be marked with a maximum set pressure not to exceed the maximum working pressure of the water heater. The combination temperature and pressure relief valve shall also have an hourly rated temperature steam BTU discharge capacity not less than shown in Table 4A.

Install the combination temperature and pressure relief valve into the opening provided and marked for this purpose on the water heater.

4 Domestic Side (Tank) Piping *(continued)*

NOTICE Verify that the combination temperature and pressure relief valve complies with local codes. If the combination temperature and pressure relief valve does not comply with local codes, replace it with one that does. Follow the installation instructions in this section.

Do not place a valve between the combination temperature and pressure relief valve and the tank.

Determine T&P relief valve size by the following specifications, unless they conflict with local codes:

- SIT030/040/050 - 3/4" NPT with a minimum AGA Rating of 105,000 Btu/hr.
- SIT065/080/119 - 3/4" NPT with a minimum AGA Rating of 200,000 Btu/hr.

NOTICE The Lochinvar SIT series water heaters will absorb/store less than 200,000 Btu/hr when domestic water outlet temperature is 210°F and boiler water supply temperature is 240°F. Listed outputs are based on ASME Section VIII Interpretation VIII-1-86-136. Check with local codes for applicability.

Table 4A Minimum Relief Valve (CSA Rating)	
Model	Btu/hr
SIT030	105,000
SIT040	105,000
SIT050	105,000
SIT065	200,000
SIT080	200,000
SIT119	200,000

Standard Installation

- Install the T&P relief valve in the connection marked "Relief Valve".

T&P Relief Valve Discharge Piping

T&P relief valve discharge piping **must** be:

- made of material serviceable for a temperature of 250°F or greater.
- directed so that hot water flows away from all persons.
- directed to a suitable place for disposal.
- installed so as to allow complete draining of the T&P relief valve and discharge line.
- terminated within 6" of the floor.

T&P relief valve discharge piping **must not** be:

- excessively long. Using more than two (2) elbows or 15 feet of piping can reduce discharge capacity.
- directly connected to a drain. Refer to local codes.
- subject to freezing.

WARNING Do not install any valve between the T&P relief valve and the tank connection or on the T&P relief valve discharge piping. Improper placement and piping of T&P relief valve can cause severe personal injury, death or substantial property damage.

CAUTION The T&P relief valve is not intended for constant duty, such as relief of pressure due to repeated normal system expansion. Correct this condition by installing a properly sized expansion tank in a domestic water system. Refer to the expansion tank manufacturer's installation instructions for proper sizing.

WARNING Failure to install and maintain a new, listed 3/4" X 3/4" temperature and pressure relief valve will release the manufacturer from any claim which might result from excessive temperature and pressures.

4 Domestic Side (Tank) Piping

Figure 4-2 Recommended Domestic Water Piping

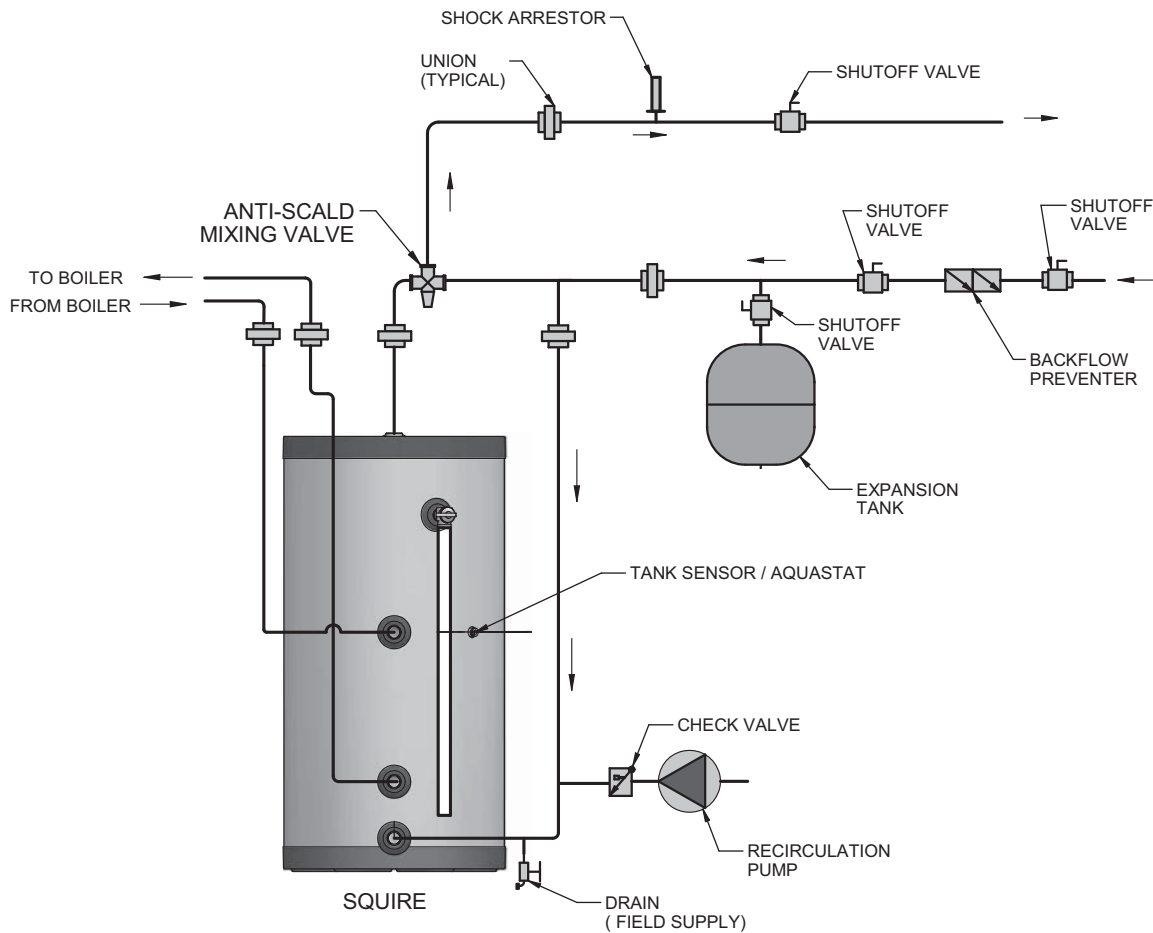

NOTICE Please note that these illustrations are meant to show system piping concept only, the installer is responsible for all equipment and detailing required by local codes.

5 Wiring

Indirect Water Heater Sensor Setup (Knight Boiler)

CAUTION

Label all wires prior to disconnection when servicing controls. Wiring errors can cause improper and dangerous operation.

NOTICE

The sensor supplied contains an Auto Reset High Limit (194°F).

Install Tank Sensor

The tank sensor is a dual sensor which controls the temperature of the tank from the boiler (see FIG. 4-1). The tank sensor has a built-in high temperature limit with a maximum setpoint of 194°F.

1. Install the sensor inside the tank as depicted in FIG. 5-1.
2. Connect the wire leads to the DHW Tank Sensor (AUX) connection point on the Knight boiler connection board (see FIG. 5-1).
3. The Knight boiler will automatically read the sensor and default the tank temperature setting to 125°F.
4. Adjust the tank setpoint program. Reference the Knight Installation and Operation Manual for a detailed explanation of the tank setpoint program.

Figure 5-1 Indirect Water Heater Controlled Using Tank Sensor

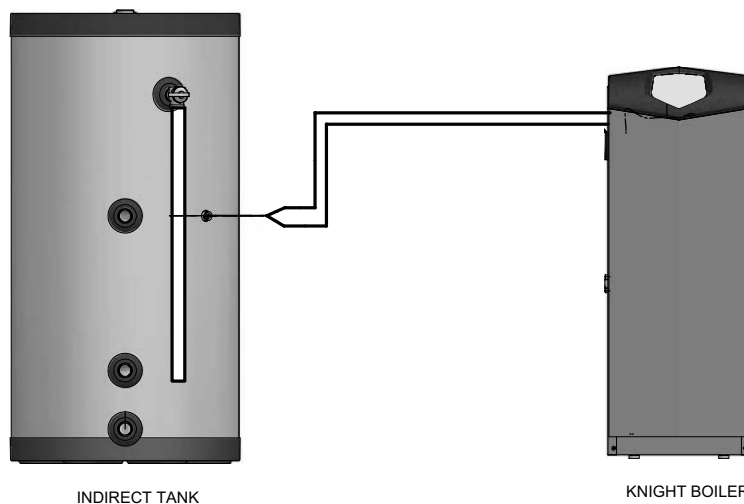
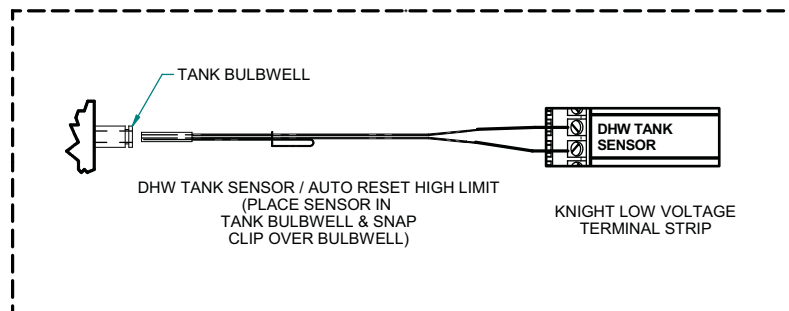

5 Wiring

Indirect Water Heater Controlled Using Aquastat and Zone Circulator / Valve

1. Install Aquastat to tank. Aquastat control (TST20016) can be ordered from your local Lochinvar distributor.
2. Connect Aquastat to the zone controller for the Indirect Water Heater Zone.
3. Adjust Aquastat to the desired temperature.

Figure 5-2 Wiring for Zone Control

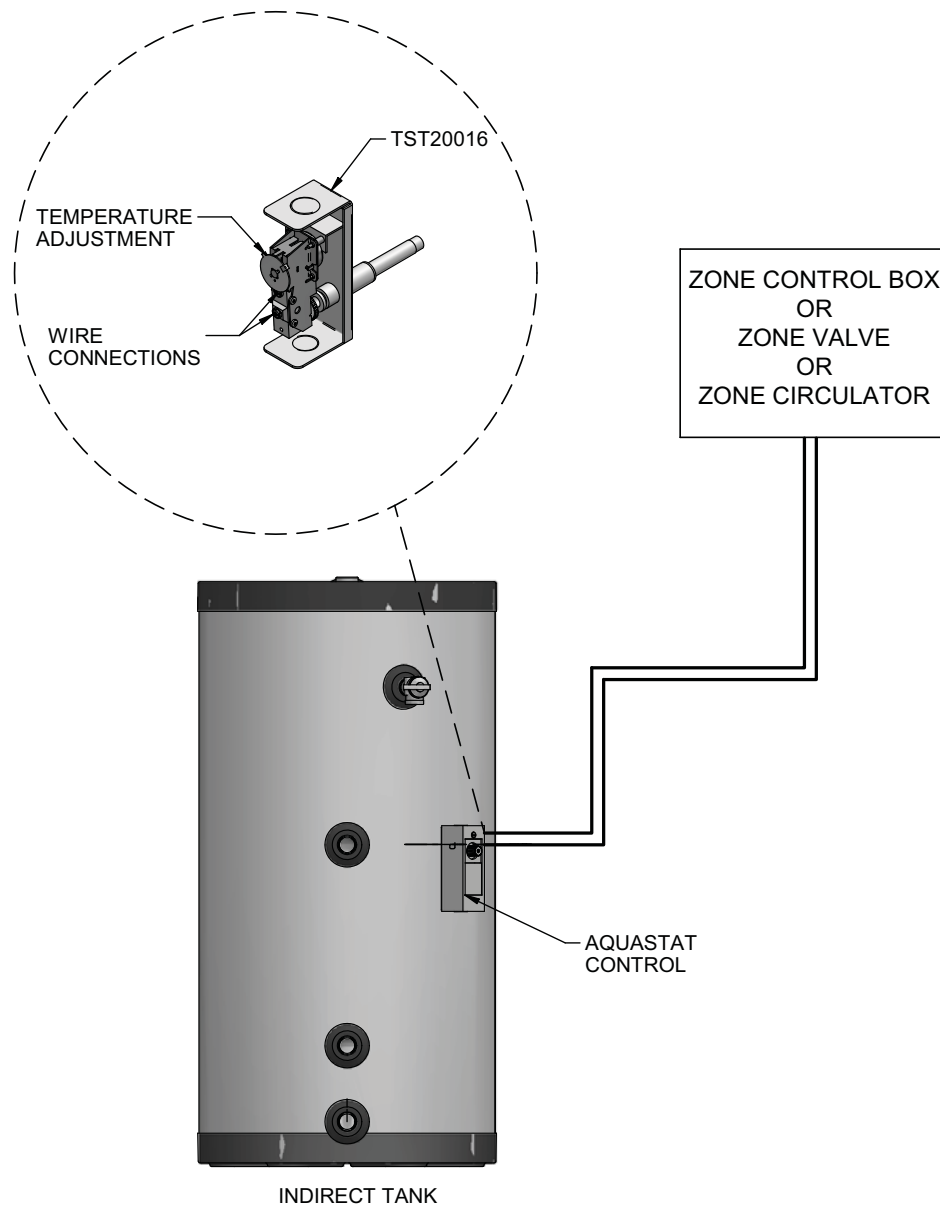

6 Start-up and Check-out

1. Make sure the system is free of leaks and that air is purged from the system.

CAUTION

Fix any leaks found before proceeding further. Leakage from the boiler piping can result in severe damage to the boiler.

2. Many soldering fluxes contain Zinc Chloride which can cause severe corrosion damage to stainless steel. After completing all domestic water connections, flush the indirect water heater thoroughly before leaving the installation. This is particularly important if the indirect water heater will be unused for an extended period of time after installation. Flush the indirect water heater by drawing at least three times its volume from the tank.
3. Make sure that all electrical connections are made correctly and that no exposed high voltage wiring is present.
4. Make sure that each zone valve or circulator operates when, and only when, its thermostat calls for heat. Let each zone operate long enough to purge any remaining air from the system.
5. Set the indirect water heater to the desired temperature. Because hot water presents a scald hazard, it is best to set the thermostat at 120°F or lower and raise it only if necessary to provide adequate hot water.
6. Re-enable the burner and allow the boiler to operate. Make sure that the boiler shuts down when the indirect water heater is satisfied.

7 Maintenance

The Lochinvar SIT series indirect water heater is an extremely simple device and as such requires very little maintenance. There are, however, several items which should be checked out on an annual or as needed basis to ensure a reliable supply of hot water:

- * Make sure that the rest of the boiler and domestic water piping is free of leaks.
- * If there is an oil lubricated circulator in the system, make sure it is lubricated as called for by the circulator manufacturer.
- * The indirect water heater depends upon the boiler for a source of heat and is therefore only as reliable as the boiler.
- * Make sure that the boiler is maintained in accordance with the boiler manufacturer's instructions.
- * If a water treatment system is required to keep the water chemistry within the parameters shown in Table 2A (see Section 2 - Pre-Installation), make sure that this system is properly maintained.

Maintenance Schedule

Annual service by a qualified service technician should include the following:

- Any procedure required by local codes.
- Verify system pressure. Air venting procedure may require adding water to bring boiler system up to pressure, typically 12 psig.
- Manually operate T&P relief valve at least once a year. This will release some hot water.

⚠ WARNING

Before operating a T&P relief valve, make sure no one is in front of or around the T&P relief valve discharge piping. Hot discharge water can cause severe personal injury or substantial property damage.

- Move operating lever to open position for a few seconds and then move it back, allowing it to snap closed. After the T&P relief valve is operated, if it continues to release water, close the cold water inlet to the water heater immediately. Follow the draining instructions, and replace the T&P relief valve. If the T&P relief valve weeps periodically, it may be due to thermal expansion. Do not plug the T&P relief valve or discharge piping.

⚠ DANGER

Plugging the T&P relief valve or discharge piping can cause excessive pressure in the water heater, resulting in severe personal injury, death, or substantial property damage.

- Follow instructions on circulator to oil, if required.
- Check mixing valve, valves, pipes, and fittings for leaks.
- Check function of the field-installed controls and valves. See component manufacturer's instructions.

- Review homeowner's maintenance responsibilities and their frequencies, including any not listed in the following section.

Homeowner monthly maintenance to include:

- Visually check valves, pipes, and fittings for leaks. Call a qualified service technician to repair leaks.

To Fill the Water Heater

1. Close the water heater drain valve by turning the knob clockwise.
2. Open the cold water supply shutoff valve.
3. Open several hot water faucets to allow air to escape from the system.
4. When a steady stream of water flows from the faucets, the water heater is filled. Close the faucets and check for water leaks at the water heater drain valve, combination temperature and pressure relief valve and the hot and cold water connections.

⚠ WARNING

Water from opened drain valves, unions and other connections may be extremely hot. To avoid severe personal injury, death, or substantial property damage:

- Tighten all drain hose connections.
- Direct hot water away from all persons.

To Drain the Water Heater

Should it become necessary to completely drain the water heater, be sure to follow the steps below:

1. Disconnect the power supply to the heat source. Consult the plumbing professional or electric company in your area for service.
2. Close the cold water supply shutoff valve.
3. Open the drain valve on the water heater.
4. Open a hot water faucet to allow air to enter the system.

Drain the water heater if it will be shut off and exposed to freezing temperatures. Freezing water will expand and damage the water heater.

- If boiler water contains sufficient antifreeze, then only the domestic water needs to be drained.
- If boiler water does not contain sufficient antifreeze, the boiler water and the domestic water must be drained.

If antifreeze is used in the boiler water, check concentration. Boiler water (including additives) must be practically non-toxic, having a toxicity rating or class of 1, as listed in the "Clinical Toxicology of Commercial Products". A maximum 50/50 mixture of inhibited propylene glycol is recommended. Follow the antifreeze manufacturer's instructions.

⚠ WARNING

Do not use automotive, ethylene glycol or petroleum-based antifreeze. Do not use any undiluted antifreeze. This can cause severe personal injury, death, or substantial property damage.

8 Performance Data

Table 8A IBR Chart

 Squire Indirect Water Heater I=B=R Rating								
Indirect Water Heater Model Number	Potable Water Volume Gal.	Heat Source Water Volume Gal.	Standby Heat Loss F/hr	Continuous Draw Rating Gal/hr	First Hour Rating Gal/hr	Minimum Heat Output Rate from Heat Source Btu/hr	Minimum Heat Source Flow Rate GPM	Tank Heat Source Friction Loss Feet W.C.
SIT030	27.0	1.1	1.2	160	183	99,000	14.0	3.9
SIT040	40.0	1.6	0.7	181	208	115,000	14.0	4.5
SIT050	51.6	1.7	0.6	209	255	133,000	14.0	5.3
SIT065	67.0	1.9	0.5	263	327	154,000	14.0	5.7
SIT080	81.5	2.1	0.5	266	347	160,000	14.0	5.7
SIT119	113.4	3.2	0.4	349	459	216,000	14.0	6.5

• These ratings were obtained with a heat source output and heat source flow rate as listed in the chart using the parameters of the Domestic Cold Water Inlet at 58°F, Domestic Temperature Rise of 77°F, and a Boiler Temperature Output of 180°F. Other results will be obtained under different conditions.

8 Performance Data *(continued)*

How to Properly Size Your Indirect Water Heater

Use the First Hour Rating (FHR) to properly size your Indirect Water Heater. The First Hour Rating is the amount of hot water in gallons the heater can supply per hour (starting with a tank full of hot water), depending on tank capacity, source of heat, and the size of the burner.

Estimate your peak hour demand as follows:

- Determine what time of day (morning, noon, evening) you use the most hot water in your home. Keep in mind the number of people living in your home.
- Use the worksheet below to estimate your maximum usage of hot water during this one hour of the day -- this is your peak hour demand. **Note:** The worksheet does not estimate total daily hot water usage.

The worksheet example shows a total peak hour demand of 165 gallons; therefore, this household would need a water heater with a First Hour Rating of no less than 165 gallons.

Fixture Count Guide

To quickly estimate the minimum gallons of hot water required based on a family size number of baths and hot water appliances the First Hour Rating of the Squire must be equal to or exceed the total first hour requirements.

Peak Hour Demand Worksheet				
Description	Fill in the Blank		Example	
40 Gallons for the first 2 people	_____	Gals.	<u>40</u>	Gals.
10 Gallons for each additional person	_____	Gals.	<u>20</u>	Gals.
20 Gallons for each bath after the first (consecutive bath)	_____	Gals.	<u>20</u>	Gals.
10 Gallons if dishwasher is used	_____	Gals.	<u>10</u>	Gals.
20 Gallons if clothes washer is used	_____	Gals.	<u>20</u>	Gals.
TOTAL	_____	Gals.	<u>110</u>	Gals.
Heavy Usage Buffer Use if family members take longer than average showers, etc.	<u>x 1.5</u>		<u>x 1.5</u>	
First Hour Rating	_____	Gals.	165	Gals.

Proceed to pages 21 – 23 of this manual to locate your Indirect Water Heater and Boiler in the sizing charts. Using the First Hour Rating calculated in this worksheet, locate your Indirect Water Heater and Boiler along with your First Hour Rating. This will also determine the flow needed between the Indirect Water Heater and Boiler.

8 Performance Data

Table 8B First Hour Rating - 180°F Boiler Loop Water (Knight Boiler)

First Hour Rating - 180°F Boiler Loop Water (Knight Boiler - Models SIT030 - SIT050)																														
Model	SIT030					SIT040					SIT050																			
Circulator Flow GPM	5		8		12		16		20		5		8		12		16		20											
Domestic Outlet	115	140	115	140	115	140	115	140	115	140	115	140	115	140	115	140	115	140	115	140	115	140								
Boiler Heating Capacity	WB050	108	83	108	83						122	97	122	97						135	110	135	110							
	K/WB080	159	119	159	119						173	133	173	133						188	147	188	147							
	K/WB105	171	128	191	142						217	165	217	165						231	178	231	178							
	K/WB150			191	142	223	165						252	189	267	200						268	204	292	221					
	K/WB210				223	165	240	177						267	200	282	211						292	221	307	232				
	KB285				223	165	240	177	267	196				267	200	282	211	286	213						292	221	307	232	334	251
	KB399								267	196								286	213								334	251		
	KB500								267	196								286	213								334	251		
MAX BTU INPUT	77008		89165		105532		114761		129676		92998		112972		123331		129574		132764		94115		114116		125111		134044		146207	

First Hour Rating - 180°F Boiler Loop Water (Knight Boiler - SIT065 - SIT119)																														
Model	SIT065					SIT080					SIT119																			
Circulator Flow GPM	5		8		12		16		20		5		8		12		16		20											
Domestic Outlet	115	140	115	140	115	140	115	140	115	140	115	140	115	140	115	140	115	140	115	140	115	140	115	140	115	140	115	140		
Boiler Heating Capacity	WB050	153	128	153	128						163	138	163	138						197	172	197	172							
	K/WB080	207	165	207	165						216	175	216	175						250	209	250	209							
	K/WB105	250	196	250	196						259	206	259	206						292	239	292	239							
	K/WB150			319	245	328	252						338	262	338	262						372	296	372	296					
	K/WB210				356	271	386	293						374	288	409	312						476	371	476	371				
	KB285				356	271	386	293	388	294				374	288	409	312	424	323						501	388	573	438	596	454
	KB399								388	294								323								596	454			
	KB500								388	294								323								596	454			
MAX BTU INPUT	118488		129139		146864		163768		167924		115860		139106		154002		171229		181544		141419		190161		204795		237649		253504	

8 Performance Data *(continued)*

Table 8C First Hour Rating - 180°F Boiler Loop Water (Universal Sizing)

First Hour Rating - 180°F Boiler Loop Water (Universal Sizing - 45,000 - 295,000 Btu/hr)																																
Model	SIT030					SIT040					SIT050																					
Circulator Flow GPM	5		8		12		16		20		5		8		12		16		20													
Domestic Outlet	115	140	115	140	115	140	115	140	115	140	115	140	115	140	115	140	115	140	115	140												
Boiler Heating Capacity	45,000	108	83	108	83						122	97	122	97						135	110	135	110									
	60,000	136	103	136	103						150	118	150	118						164	131	164	131									
	75,000	165	123	165	123						179	138	179	138						194	151	194	151									
	95,000	171	128	191	142	202	150				217	165	217	165	217	165				233	179	233	179	233	179							
	115,000	171	128	191	142	223	165	240	177			217	165	252	189	252	189	252	189			233	179	268	204	273	207	273	207			
	140,000			191	142	223	165	240	177	267	196			252	189	267	200	282	211	286	208			268	204	292	221	307	232	322	242	
	165,000							240	177	267	196						267	200	282	211	286	213					292	221	307	232	334	251
	195,000																															
	225,000																															
	260,000																															
295,000																																
MAX BTU INPUT	77008		89165		105532		114761		129676		92998		112972		123331		129574		132764		94115		114116		125111		134044		146207			

First Hour Rating - 180°F Boiler Loop Water (Universal Sizing - 45,000 - 295,000 Btu/hr)																																	
Model	SIT065					SIT080					SIT119																						
Circulator Flow GPM	5		8		12		16		20		5		8		12		16		20														
Domestic Outlet	115	140	115	140	115	140	115	140	115	140	115	140	115	140	115	140	115	140	115	140													
Boiler Heating Capacity	45,000	153	128	153	128						163	138	163	138						197	172	197	172										
	60,000	183	149	183	149						193	159	193	159						226	193	226	193										
	75,000	213	170	213	170						222	180	222	180						255	213	255	213										
	95,000	252	197	252	197	252	197				261	207	261	207	261	207				294	241	294	241	294	241								
	115,000	291	226	291	226	291	226	291	226			300	235	300	235	300	235	300	235			333	268	333	268	333	268	333	268				
	140,000	305	235	319	245	338	259	338	259	338	259	304	238	347	268	347	268	347	268	347	268	384	302	382	302	382	302	382	302	382	302		
	165,000	305	235	319	245	356	271	386	293	388	294	304	238	349	270	374	288	395	302	395	302	387	306	429	337	429	337	429	337	429	337		
	195,000			319	245	356	271	386	293	388	294			349	270	374	288	409	312	424	323			483	375	485	376	485	376	485	376		
	225,000					356	271	386	293	388	294						374	288	409	312	424	323					501	388	548	421	541	416	
	260,000									388	294										424	323									573	438	596
295,000																																	
MAX BTU INPUT	118488		129139		146864		163768		167924		115860		139106		154002		171229		181544		141419		190161		204795		237649		253504				

8 Performance Data

Table 8D First Hour Rating 200°F Boiler Loop Water (Universal Sizing)

First Hour Rating - 200°F Boiler Loop Water (Universal Sizing - 45,000 - 295,000)																																																
Model	SIT030					SIT040					SIT050																																					
Circulator Flow GPM	5		8		12		16		20		5		8		12		16		20																													
Domestic Outlet	115	140	115	140	115	140	115	140	115	140	115	140	115	140	115	140	115	140	115	140																												
Boiler Heating Capacity	45,000	105	84	105	84						118	97	118	97						132	109	132	109																									
	60,000	133	104	133	104						145	117	145	117						160	130	160	130																									
	75,000	160	124	160	124						173	137	173	137						188	151	188	151																									
	95,000	197	151	197	151	197	151				209	163	209	163	209	163				226	179	226	179	226	179																							
	115,000	224	171	233	176	233	176	233	176			245	190	245	190	245	190	245	190			263	206	263	206	263	206	263	206																			
	140,000			255	194	277	210	277	210	277	210	271	209	291	224	291	224	291	224	291	224	295	230	311	241	311	241	311	241																			
	165,000				277	210	308	232	317	240				335	256	335	256	335	256	295	230	329	254	358	276	358	276	358	276																			
	195,000					308	232	352	265				335	256	362	276	375	285				329	254	375	288	399	306	404	309																			
	225,000																					375	288	399	306	404	309																					
	260,000																															404	309															
295,000																																																
325,000																																																
MAX BTU INPUT	107695		126355		140102		153900		184539		129980		151466		164149		178059		186356		131965		159672		172739		187562		189713																			

First Hour Rating - 200°F Boiler Loop Water (Universal Sizing - 45,000 - 295,000)																																	
Model	SIT065					SIT080					SIT119																						
Circulator Flow GPM	5		8		12		16		20		5		8		12		16		20														
Domestic Outlet	115	140	115	140	115	140	115	140	115	140	115	140	115	140	115	140	115	140	115	140													
Boiler Heating Capacity	45,000	150	127	150	127						161	138	161	138						194	171	194	171										
	60,000	179	148	179	148						189	159	189	159						222	192	222	192										
	75,000	207	169	207	169						218	180	218	180						250	213	250	213										
	95,000	245	197	245	197	245	197				255	208	255	208	255	208				288	241	288	241	288	241								
	115,000	283	225	283	225	283	225	283	225			293	236	293	236	293	236			325	268	325	268	325	268								
	140,000	331	260	331	260	331	260	331	260	331	260	341	270	341	270	341	270	341	270	373	303	373	303	373	303	373	303						
	165,000	350	274	377	294	377	294	377	294	377	294	374	295	386	304	386	304	386	304	386	304	419	337	419	337	419	337	419	337				
	195,000	350	274	391	305	432	337	432	338	432	329	374	295	440	343	440	343	440	343	440	343	479	381	479	381	479	381	479	381				
	225,000			391	305	445	345	487	375	487	375				440	343	475	369	498	386	498	386				533	422	533	422	533	422		
	260,000					495	381	499	384				475	369	525	406	536	414				601	470	601	470	601	470	601	470				
295,000																536	414						667	519	667	519							
325,000																			536	414							688	534	695	540			
MAX BTU INPUT	146842		171693		200077		225514		235239		154198		192471		211523		237540		247474		194143		245777		282047		305766		319025				



Revision Notes: *Revision A (ECO C05265) initial release.*

Revision B (ECO C05399) addition of the Pressure Drop Chart and updates made to the Performance Data Charts.

Revision C (ECO C05587) update of tables 3A and 3B (Pressure Drop charts) on pg 6, table 4A on pg 13, the update of the "Domestic water piping" paragraph on pg 11, and the update of Performance data table 8A on pg 19.